



Low-Voltage, Bidirectional RF/Video Switch

MAX4529

General Description

The MAX4529 is a low-voltage T-switch designed for switching RF and video signals from DC to 300MHz in 50Ω and 75Ω systems. This switch is constructed in a "T" configuration, ensuring excellent high-frequency off isolation of -80dB at 10MHz.

The MAX4529 can handle Rail-to-Rail® analog signals in either direction. On-resistance (70Ω max) is flat (0.5Ω max) over the specified signal range, using ±5V supplies. The off leakage current is less than 1nA at +25°C and 20nA at +85°C.

This CMOS switch can operate with dual power supplies ranging from ±2.7V to ±6V or a single supply between +2.7V and +12V. All digital inputs have 0.8V/2.4V logic thresholds, ensuring both TTL- and CMOS-logic compatibility when using ±5V or a single +5V supply.

Features

- ◆ High 50Ω Off Isolation: -80dB at 10MHz
- ◆ DC to 300MHz -3dB Signal Bandwidth
- ◆ 70Ω Signal Paths with ±5V Supplies
- ◆ 10Ω Signal-Path Flatness with ±5V Supplies
- ◆ ±2.7V to ±6V Dual Supplies
+2.7V to +12V Single Supply
- ◆ Low Power Consumption: <1μW
- ◆ Rail-to-Rail Bidirectional Signal Handling
- ◆ >2kV ESD Protection per Method 3015.7
- ◆ TTL/CMOS-Compatible Inputs with
Single +5V or ±5V

Ordering Information

PART	TEMP. RANGE	PIN-PACKAGE	SOT TOP MARK
MAX4529CPA	0°C to +70°C	8 Plastic DIP	—
MAX4529CSA	0°C to +70°C	8 Narrow SO	—
MAX4529CUA	0°C to +70°C	8 μMAX	—
MAX4529CUT-T	0°C to +70°C	6 SOT23-6	AAAQ
MAX4529C/D	0°C to +70°C	Dice*	—
MAX4529EPA	-40°C to +85°C	8 Plastic DIP	—
MAX4529ESA	-40°C to +85°C	8 Narrow SO	—
MAX4529EUA	-40°C to +85°C	8 μMAX	—
MAX4529EUT-T	-40°C to +85°C	6 SOT23-6	AAAQ

*Contact factory for dice specifications.

Applications

RF Switching
Video Signal Routing
High-Speed Data Acquisition
Test Equipment
ATE Equipment
Networking

Pin Configurations/Functional Diagrams/Truth Table

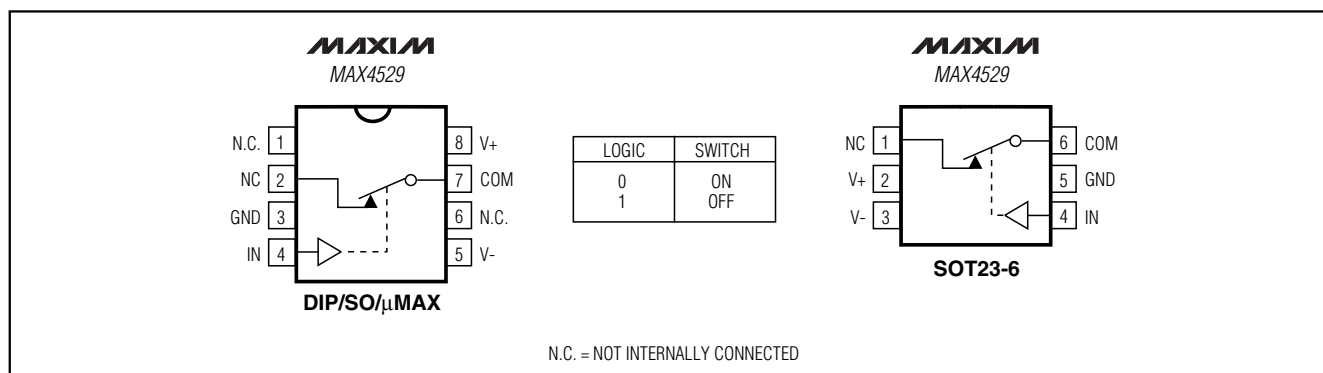

Rail-to-Rail is a registered trademark of Nippon Motorola Ltd.



Maxim Integrated Products 1

For pricing, delivery, and ordering information, please contact Maxim/Dallas Direct! at 1-888-629-4642, or visit Maxim's website at www.maxim-ic.com.

Low-Voltage, Bidirectional RF/Video Switch

ABSOLUTE MAXIMUM RATINGS

(Voltages referenced to GND)

V+	-0.3V, +13.0V
V-	-13.0V, +0.3V
V+ to V-	-0.3V, +13.0V
All Other Pins (Note 1)	(V- - 0.3V) to (V+ + 0.3V)
Continuous Current into Any Terminal	±10mA
Peak Current into Any Terminal (pulsed at 1ms, 10% duty cycle)	±50mA
ESD per Method 3015.7	>2000V

Continuous Power Dissipation (T_A = +70°C)

8-Pin Plastic DIP (derate 9.09mW/°C above +70°C)	727mW
8-Pin SO (derate 5.88mW/°C above +70°C)	471mW
8-Pin μ MAX (derate 4.1mW/°C above +70°C)	330mW
6-Pin SOT23-6 (derate 7.1mW/°C above +70°C)	571mW
Operating Temperature Ranges	
MAX4529C_E	0°C to +70°C
MAX4529E_E	-40°C to +85°C
Storage Temperature Range	-65°C to +150°C
Lead Temperature (soldering, 10s)	+300°C

Note 1: Voltages on all other pins exceeding V+ or V- are clamped by internal diodes. Limit forward diode current to maximum current rating.

Stresses beyond those listed under "Absolute Maximum Ratings" may cause permanent damage to the device. These are stress ratings only, and functional operation of the device at these or any other conditions beyond those indicated in the operational sections of the specifications is not implied. Exposure to absolute maximum rating conditions for extended periods may affect device reliability.

ELECTRICAL CHARACTERISTICS—Dual Supplies

(V+ = +4.5V to +5.5V, V- = -4.5V to -5.5V, V_{INL} = 0.8V, V_{INH} = 2.4V, V_{GND} = 0V, T_A = T_{MIN} to T_{MAX}, unless otherwise noted. Typical values are at T_A = +25°C.)

PARAMETER	SYMBOL	CONDITIONS	T _A	MIN	TYP (Note 2)	MAX	UNITS
ANALOG SWITCH							
Analog Signal Range	V _{COM} , V _{NC}	(Note 3)	C, E	V-		V+	V
Signal-Path On-Resistance	R _{ON}	V+ = 5V, V- = -5V, V _{COM} = ±3V, I _{COM} = 1mA	+25°C		45	70	Ω
			C, E			100	
Signal-Path On-Resistance Flatness (Note 4)	R _{FLAT(ON)}	V+ = 5V; V- = -5V; V _{COM} = 3V, 0V, -3V; I _{COM} = 1mA	+25°C		5	10	Ω
NC Off Leakage Current (Notes 5, 6)	I _{NC(OFF)}	V+ = 5.5V, V- = -5.5V, V _{COM} = ±4.5V, V _{NC} = ∓4.5V	+25°C	-1	0.02	1	nA
			C, E	-20		20	
COM Off Leakage Current (Notes 5, 6)	I _{COM(OFF)}	V+ = 5.5V, V- = -5.5V, V _{COM} = ±4.5V, V _{NC} = ∓4.5V	+25°C	-1	0.02	1	nA
			C, E	-20		20	
COM On Leakage Current (Notes 5, 6)	I _{COM(ON)}	V+ = 5.5V, V- = -5.5V, V _{COM} = ±4.5V	+25°C	-2	0.02	2	nA
			C, E	-40		40	
LOGIC INPUT							
IN Input Logic Threshold High	V _{INH}		C, E		1.5	2.4	V
IN Input Logic Threshold Low	V _{INL}		C, E	0.8	1.5		V
IN Input Current Logic High or Low	I _{INH} , I _{INL}	V _{IN} = 0.8V or 2.4V	C, E	-1	0.03	1	μA

Low-Voltage, Bidirectional RF/Video Switch

MAX4529

ELECTRICAL CHARACTERISTICS—Dual Supplies (continued)

(V+ = +4.5V to +5.5V, V- = -4.5V to -5.5V, V_{INL} = 0.8V, V_{INH} = 2.4V, V_{GND} = 0V, T_A = T_{MIN} to T_{MAX}, unless otherwise noted. Typical values are at T_A = +25°C.)

PARAMETER	SYMBOL	CONDITIONS	T _A	MIN	TYP (Note 2)	MAX	UNITS
SWITCH DYNAMIC CHARACTERISTICS							
Turn-On Time	t _{ON}	V _{COM} = ±3V, V+ = 5V, V- = -5V, Figure 2	+25°C	45	75	ns	
			C, E	100			
Turn-Off Time	t _{OFF}	V _{COM} = ±3V, V+ = 5V, V- = -5V, Figure 2	+25°C	37	75	ns	
			C, E	100			
Charge Injection (Note 3)	Q	C _L = 1.0nF, V _{NC} = 0V, R _S = 0Ω, Figure 3	+25°C	5	10	pC	
NC Off Capacitance	C _{NC(OFF)}	V _{NC} = GND, f = 1MHz, Figure 5	+25°C	6		pF	
COM_ Off Capacitance	C _{COM(OFF)}	V _{COM} = 0V, f = 1MHz, Figure 5	+25°C	6		pF	
COM_ On Capacitance	C _{COM(ON)}	V _{COM} = V _{NC} = 0V, f = 1MHz, Figure 5	+25°C	11.5		pF	
Off Isolation (Note 7)	V _{ISO}	R _L = 50Ω, V _{COM} = 1V _{RMS} , f = 10MHz, Figure 4	+25°C	-80		dB	
-3dB Bandwidth	BW	R _L = 50Ω, Figure 4	+25°C	300		MHz	
Distortion	THD+N	V _{IN} = 5V _{p-p} , f < 20kHz, 600Ω in and out	+25°C	0.004		%	
POWER SUPPLY							
Power-Supply Range	V+, V-		C, E	±2.7		±6	V
V+ Supply Current	I+	V+ = 5.5V, V _{IN} = 0V or V+, V- = -5.5V	+25°C	-1	0.05	1	μA
			C, E	-10		10	
V- Supply Current	I-	V+ = 5.5V, V _{IN} = 0V or V+, V- = -5.5V	+25°C	-1	0.05	1	μA
			C, E	-10		10	

Low-Voltage, Bidirectional RF/Video Switch

ELECTRICAL CHARACTERISTICS—Single +5V Supply

(V+ = +4.5V to +5.5V, V- = 0V, VINL = 0.8V, VINH = 2.4V, VGND = 0V, TA = TMIN to TMAX, unless otherwise noted. Typical values are at TA = +25°C.)

PARAMETER	SYMBOL	CONDITIONS	TA	MIN	TYP (Note 2)	MAX	UNITS
ANALOG SWITCH							
Analog Signal Range	VCOM, VNC	(Note 3)	+25°C	0		V+	V
Signal-Path On-Resistance	RON	V+ = 5V, VCOM = 3V, ICOM = 1mA	+25°C		70	120	Ω
			C, E			150	
NC Off Leakage Current (Notes 5, 6, 8)	INC(OFF)	V+ = 5.5V, VCOM = 1V, VNC = 4.5V	+25°C	-1	0.02	1	nA
			C, E	-20		20	
COM Off Leakage Current (Notes 5, 6, 8)	ICOM(OFF)	V+ = 5.5V, VCOM = 1V, VNC = 4.5V	+25°C	-1	0.02	1	nA
			C, E	-20		20	
COM On Leakage Current (Notes 5, 6, 8)	ICOM(ON)	V+ = 5.5V; VCOM = 1V, 4.5V	+25°C	-2	0.02	2	nA
			C, E	-40		40	
LOGIC INPUT							
IN Input Logic Threshold High	VINH		C, E		1.5	2.4	V
IN Input Logic Threshold Low	VINL		C, E	0.8	1.5		V
IN Input Current Logic High or Low	IINH, IINL	VIN = 0.8V or 2.4V	C, E	-1	0.03	1	μA
SWITCH DYNAMIC CHARACTERISTICS							
Turn-On Time (Note 3)	ton	VCOM = 3V, V+ = 5V, Figure 2	+25°C		65	100	ns
			C, E			120	
Turn-Off Time (Note 3)	tOFF	VCOM = 3V, V+ = 5V, Figure 2	+25°C		43	90	ns
			C, E			110	
Charge Injection (Note 3)	Q	CL = 1.0nF, VNC = 2.5V, RS = 0Ω, Figure 3	+25°C		1.5	10	pC
Off-Isolation (Note 7)	VISO	RL = 50Ω, VCOM = 1VRMS, f = 10MHz, Figure 4	+25°C		-75		dB
POWER SUPPLY							
Power-Supply Range	V+	V- = 0V	C, E	2.7		12.0	V
V+ Supply Current	I+	V+ = 5.5V, VIN = 0V or V+	+25°C	-1	0.05	1	μA
			C, E	-10		10	

Low-Voltage, Bidirectional RF/Video Switch

MAX4529

ELECTRICAL CHARACTERISTICS—Single +3V Supply

($V_+ = +2.7V$ to $+3.6V$, $V_- = 0V$, $V_{INL} = 0.4V$, $V_{INH} = 2.4V$, $V_{GND} = 0V$, $T_A = T_{MIN}$ to T_{MAX} , unless otherwise noted. Typical values are at $T_A = +25^\circ C$.)

PARAMETER	SYMBOL	CONDITIONS	T_A	MIN	TYP (Note 2)	MAX	UNITS
ANALOG SWITCH							
Analog Signal Range	V_{COM}, V_{NC}	(Note 3)	+25°C	0		V_+	V
Signal-Path On-Resistance	R_{ON}	$V_+ = 2.7V, V_{COM} = 1.5V,$ $I_{COM} = 0.1mA$	+25°C		175	400	Ω
			C, E			500	
LOGIC INPUT							
IN Input Logic Threshold High	V_{INH}	(Note 3)	C, E		1.0	2.4	V
IN Input Logic Threshold Low	V_{INL}	(Note 3)	C, E	0.4	1.0		V
IN Input Current Logic High or Low	I_{INH}, I_{INL}	$V_{IN} = 0.4V$ or $2.4V$ (Note 3)	C, E	-1		1	μA
SWITCH DYNAMIC CHARACTERISTICS							
Turn-On Time	t_{ON}	$V_{COM} = 1.5V, V_+ = 2.7V,$ Figure 2 (Note 3)	+25°C		150	300	ns
			C, E			400	
Turn-Off Time	t_{OFF}	$V_{COM} = 1.5V, V_+ = 2.7V,$ Figure 2 (Note 3)	+25°C		70	150	ns
			C, E			200	
POWER SUPPLY							
V_+ Supply Current	I_+	$V_+ = 3.6V, V_{IN} = 0V$ or V_+	+25°C	-1	0.05	1	μA
			C, E	-10		10	

Note 2: The algebraic convention is used in this data sheet; the most negative value is shown in the minimum column.

Note 3: Guaranteed by design.

Note 4: Resistance flatness is defined as the difference between the maximum and the minimum value of on-resistance as measured over the specified analog signal range.

Note 5: Leakage parameters are 100% tested at the maximum rated hot temperature and guaranteed by correlation at +25°C.

Note 6: Guaranteed by design, not subject to production testing in SOT package.

Note 7: Off isolation = $20 \log_{10} (V_{COM} / V_{NC})$, V_{COM} = output, V_{NC} = input to off switch.

Note 8: Leakage testing for single-supply operation is guaranteed by testing with dual supplies.

Typical Operating Characteristics

($V_+ = +5V, V_- = -5V, GND = 0V, T_A = +25^\circ C$, packages are surface mount, unless otherwise noted.)

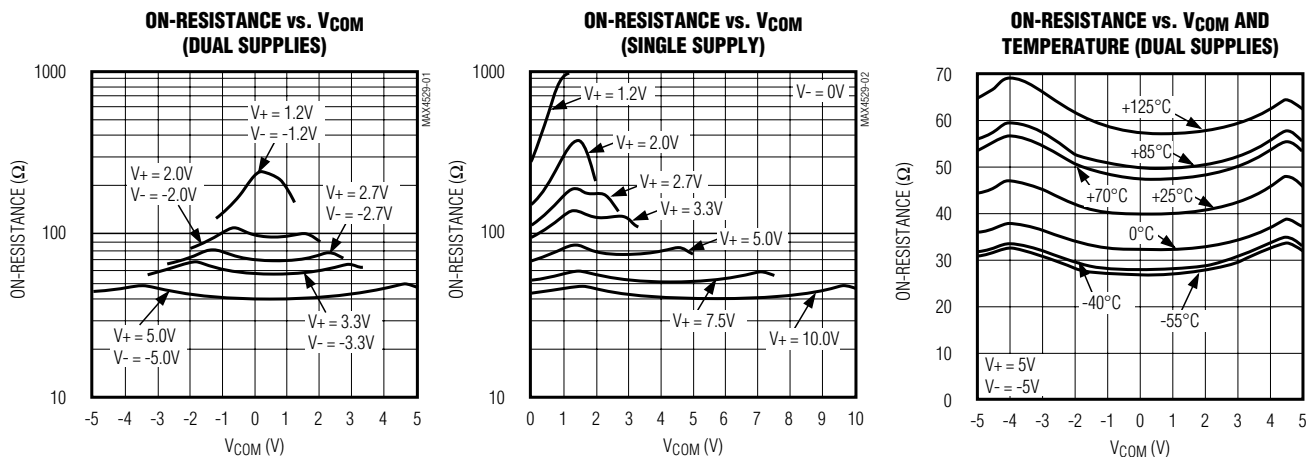

Low-Voltage, Bidirectional RF/Video Switch

Typical Operating Characteristics (continued)

($V_+ = +5V$, $V_- = -5V$, GND = 0V, $T_A = +25^\circ C$, packages are surface mount, unless otherwise noted.)

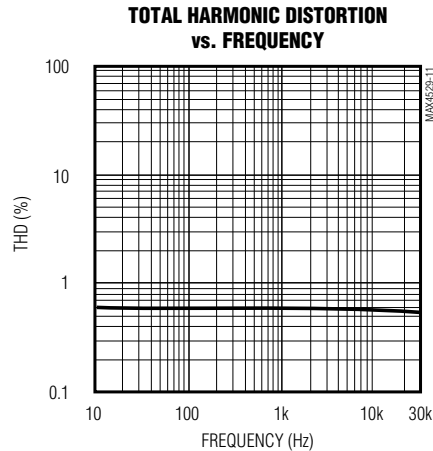
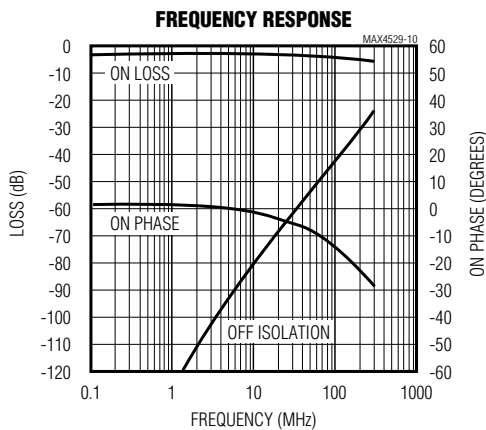
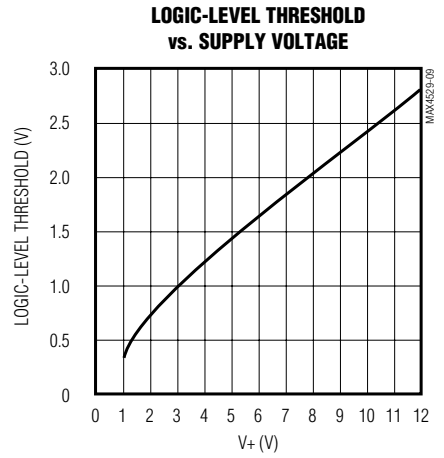
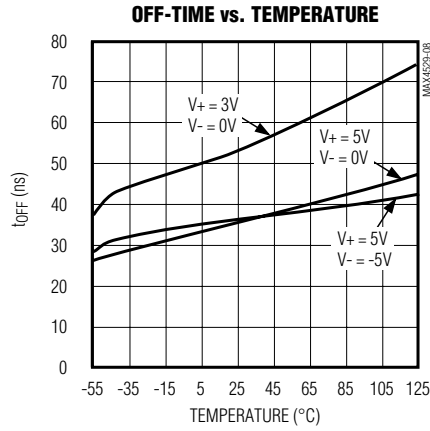
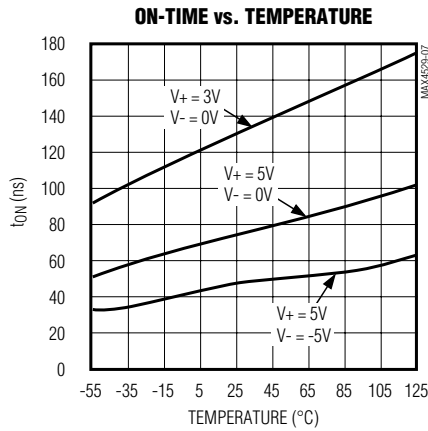
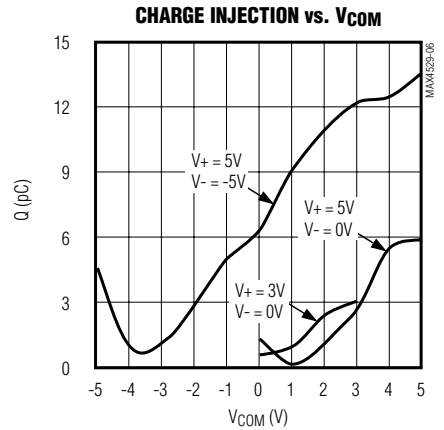
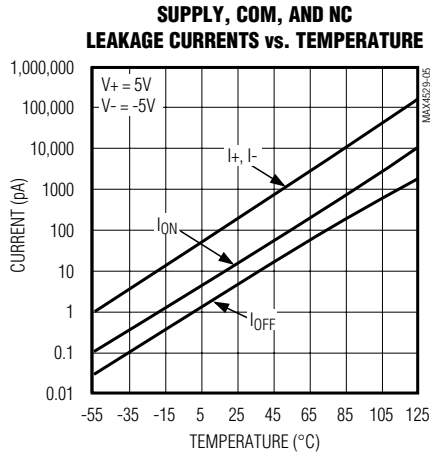
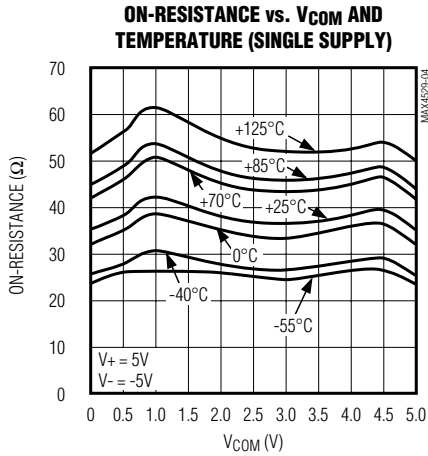

Low-Voltage, Bidirectional RF/Video Switch

The MAX4529 is optimized for $\pm 5V$ operation. Using lower supply voltages or a single supply increases switching time, on-resistance (and therefore on-state attenuation), and nonlinearity.

Switch Off Condition

When the switch is off, MOSFETs N1, N2, P1, and P2 are off and MOSFET N3 is on. The signal path is through the off-capacitances of the series MOSFETs, but it is shunted to ground by N3. This forms a high-pass filter whose exact characteristics depend on the source and load impedances. In 50Ω systems, and below 10MHz, the attenuation can exceed 80dB. This value decreases with increasing frequency and increasing circuit impedances. External capacitance and board layout have a major role in determining overall performance.

Applications Information

Power-Supply Considerations

Overview

The MAX4529's construction is typical of most CMOS analog switches. It has three supply pins: V+, V-, and GND. V+ and V- are used to drive the internal CMOS switches and set the limits of the analog voltage on any switch. Reverse ESD protection diodes are internally connected between each analog signal pin and both V+ and V-. If the voltage on any pin exceeds V+ or V-, one of these diodes will conduct. During normal operation these reverse-biased ESD diodes leak, forming the only current drawn from V-.

Virtually all the analog leakage current is through the ESD diodes. Although the ESD diodes on a given signal pin are identical, and therefore fairly well balanced, they are reverse biased differently. Each is biased by either V+ or V- and the analog signal. This means their leakages vary as the signal varies. The *difference* in the two diode leakages from the signal path to the V+ and V- pins constitutes the analog signal-path leakage current. All analog leakage current flows to the supply terminals, not to the other switch terminal. This explains how both sides of a given switch can show leakage currents of either the same or opposite polarity.

When the switch is on, there is no connection between the analog signal paths and GND. The analog signal paths consist of an N-channel and P-channel MOSFET with their sources and drains paralleled and their gates driven out of phase with V+ and V- by the logic-level translators.

V+ and GND power the internal logic and logic-level translators, and set the input logic thresholds. The logic-level translators convert the logic levels to

switched V+ and V- signals to drive the gates of the analog switches. This drive signal is the only connection between the logic supplies and the analog supplies. All pins have ESD protection to V+ and to V-.

Increasing V- has no effect on the logic-level thresholds, but it does increase the drive to the P-channel switches, reducing their on-resistance. V- also sets the negative limit of the analog signal voltage.

The logic-level thresholds are CMOS and TTL compatible when V+ is +5V. As V+ is raised, the threshold increases slightly; when V+ reaches +12V, the level threshold is about 3.1V, which is above the TTL output high-level minimum of 2.8V, but still compatible with CMOS outputs.

Bipolar-Supply Operation

The MAX4529 operates with bipolar supplies between $\pm 2.7V$ and $\pm 6V$. The V+ and V- supplies need not be symmetrical, but their sum cannot exceed the absolute maximum rating of 13.0V. **Do not connect the MAX4529 V+ pin to +3V and connect the logic-level input pins to TTL logic-level signals. TTL logic-level outputs can exceed the absolute maximum ratings, causing damage to the part and/or external circuits.**

CAUTION:

The absolute maximum V+ to V- differential voltage is 13.0V. Typical “ ± 6 -Volt” or “12-Volt” supplies with $\pm 10\%$ tolerances can be as high as 13.2V. This voltage can damage the MAX4529. Even $\pm 5\%$ tolerance supplies may have overshoot or noise spikes that exceed 13.0V.

Single-Supply Operation

The MAX4529 operates from a single supply between +2.7V and +12V when V- is connected to GND. All of the bipolar precautions must be observed. Note, however, that these parts are optimized for $\pm 5V$ operation, and most AC and DC characteristics are degraded significantly when departing from $\pm 5V$. As the overall supply voltage (V+ to V-) is lowered, switching speed, on-resistance, off isolation, and distortion are degraded (see *Typical Operating Characteristics*).

Single-supply operation also limits signal levels and interferes with grounded signals. When V- = 0V, AC signals are limited to -0.3V. Voltages below -0.3V can be clipped by the internal ESD-protection diodes, and the parts can be damaged if excessive current flows.

Low-Voltage, Bidirectional RF/Video Switch

MAX4529

Single-Supply Operation Above 5V

The MAX4529 is designed for operation from single +5V or dual $\pm 5V$ supplies. As V_+ is increased above 5V, the logic-level threshold voltage increases and the supply current increases. In addition, if the logic levels are not driven rail-to-rail, the analog signal pins, COM and NC, can conduct a significant DC current (up to 1mA) to the supply pins. This current can add an unwanted DC bias to the signal. Therefore, when operating V_+ above 5V, always drive the IN pin rail-to-rail.

Power Off

When power to the MAX4529 is off (i.e., $V_+ = 0V$ and $V_- = 0V$), the Absolute Maximum Ratings still apply. This means that neither logic-level inputs on IN nor signals on COM or NC can exceed $\pm 0.3V$. Voltages beyond $\pm 0.3V$ cause the internal ESD-protection diodes to conduct, and the parts can be damaged if excessive current flows.

Grounding

DC Ground Considerations

Satisfactory high-frequency operation requires that careful consideration be given to grounding. **For most applications, a ground plane is strongly recommended, and GND should be connected to it with solid copper.**

In systems that have separate digital and analog (signal) grounds, connect these switch GND pins to analog ground. Preserving a good signal ground is much more important than preserving a digital ground. Ground current is only a few nanoamps.

The logic-level input, IN, has voltage thresholds determined by V_+ and GND. (V_- does not influence the logic-level threshold.) With +5V and 0V applied to V_+ and GND, the threshold is about 1.6V, ensuring compatibility with TTL- and CMOS-logic drivers.

The GND pin can be connected to separate voltage potentials if the logic-level input is not a normal logic signal. (The GND voltage cannot exceed $(V_+ - 2V)$ or V_- .) Elevating GND reduces off isolation. Note, however, that IN can be driven more negative than GND, as far as V_- . GND does not have to be removed from 0V when IN is driven from bipolar sources, but the voltage on IN should never exceed V_- . GND should be separated from 0V only if the logic-level threshold has to be changed.

If the GND pin is not connected to 0V, it should be bypassed to the ground plane with a surface-mount 10nF capacitor to maintain good RF grounding. DC current in the IN and GND pins is less than 1nA, but increases with switching frequency.

AC Ground and Bypassing

A ground plane is mandatory for satisfactory high-frequency operation. (Prototyping using hand wiring or wire-wrap boards is strongly discouraged.) Connect any 0V GND pins to the ground plane with solid copper. (The GND pin extends the high-frequency ground through the package wire-frame, into the silicon itself, thus improving isolation.) The ground plane should be solid metal underneath the device, without interruptions. There should be no traces under the device itself. For DIP packages, this applies to both sides of a two-sided board. Failure to observe this will have a minimal effect on the "on" characteristics of the switch at high frequencies, but it will degrade the off isolation and crosstalk.

V_+ and V_- pins should be bypassed to the ground plane with surface-mount 10nF capacitors. For DIP packages, they should be mounted as close as possible to the pins on the same side of the board as the device. Do not use feedthroughs or vias for bypass capacitors. For surface-mount packages, the pins are so close to each other that the bypass capacitors should be mounted on the opposite side of the board from the device. In this case, use short feedthroughs or vias, directly under the V_+ and V_- pins. Any GND pin not connected to 0V should be similarly bypassed. If V_- is 0V, connect it directly to the ground plane with solid copper. Keep all leads short.

Signal Routing

Keep all signal leads as short as possible. Separate all signal leads from each other and other traces with the ground plane on both sides of the board. Where possible, use coaxial cable instead of printed circuit board traces.

Board Layout

IC sockets degrade high-frequency performance and should not be used if signal bandwidth exceeds 5MHz. Surface-mount parts, having shorter internal lead frames, provide the best high-frequency performance. Keep all bypass capacitors close to the device, and separate all signal leads with ground planes. Such grounds tend to be wedge-shaped as they get closer to the device. Use vias to connect the ground planes on each side of the board, and place the vias in the apex of the wedge-shaped grounds that separate signal leads. Logic-level signal lead placement is not critical.

Low-Voltage, Bidirectional RF/Video Switch

Test Circuits/Timing Diagrams

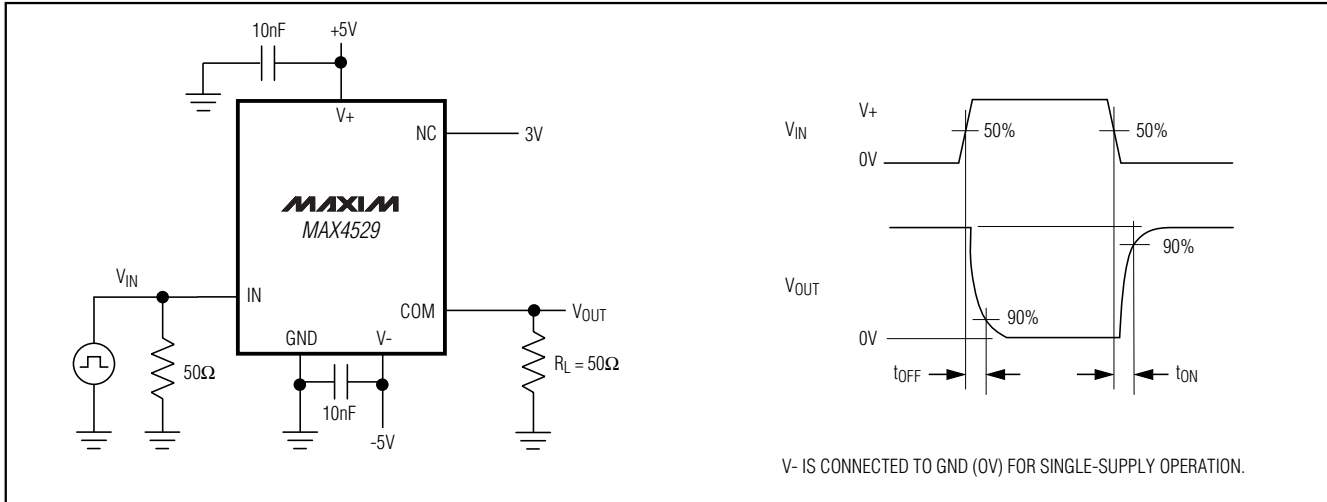

Figure 2. Switching Time

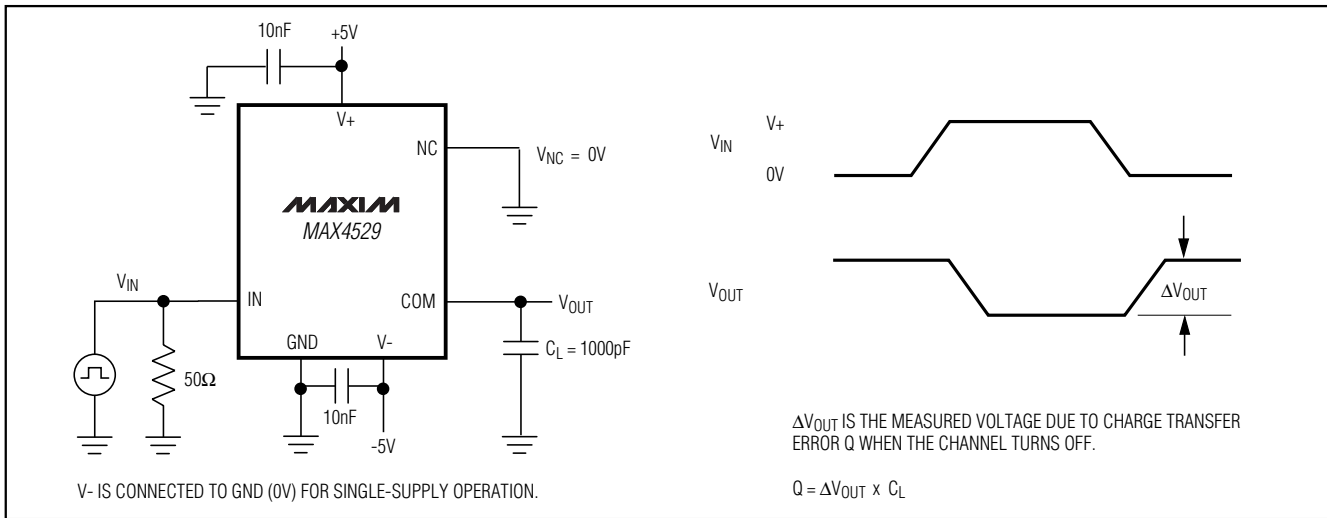

Figure 3. Charge Injection

Low-Voltage, Bidirectional RF/Video Switch

MAX4529

Test Circuits/Timing Diagrams (continued)

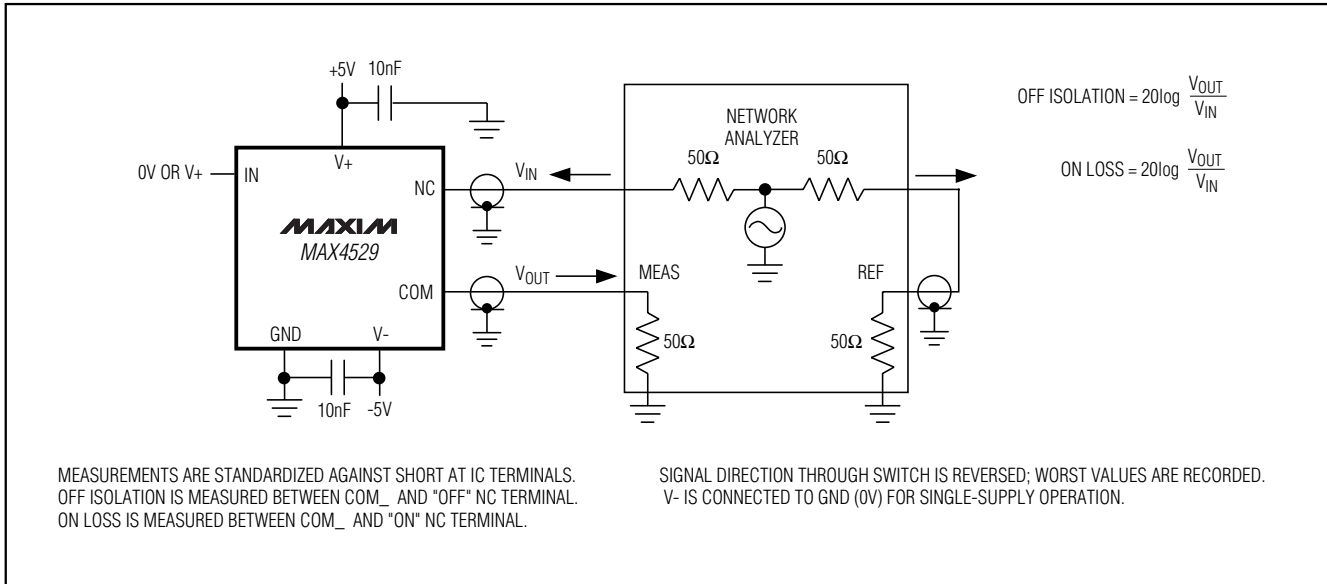

Figure 4. On Loss and Off Isolation

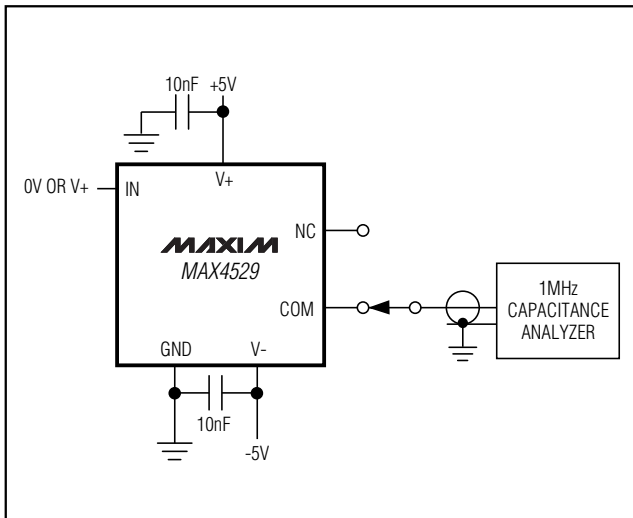
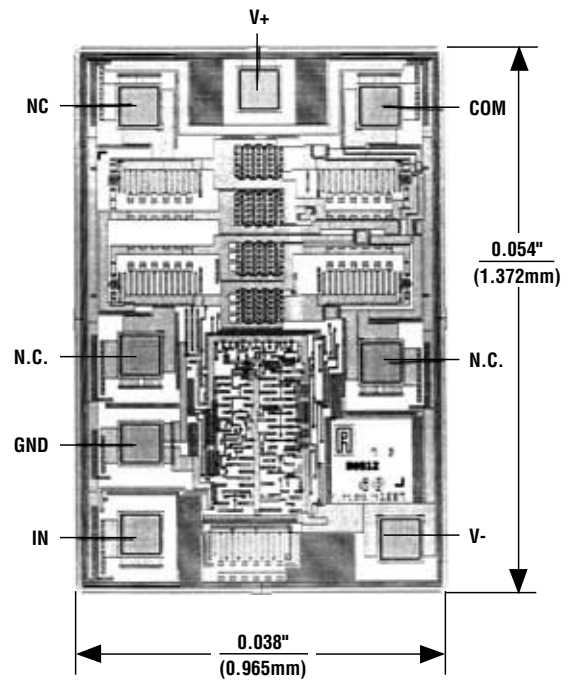

Figure 5. NC and COM Capacitance

Chip Topography



TRANSISTOR COUNT: 78
 SUBSTRATE INTERNALLY CONNECTED TO V+
 N.C. = NO CONNECTION

Low-Voltage, Bidirectional RF/Video Switch

Package Information

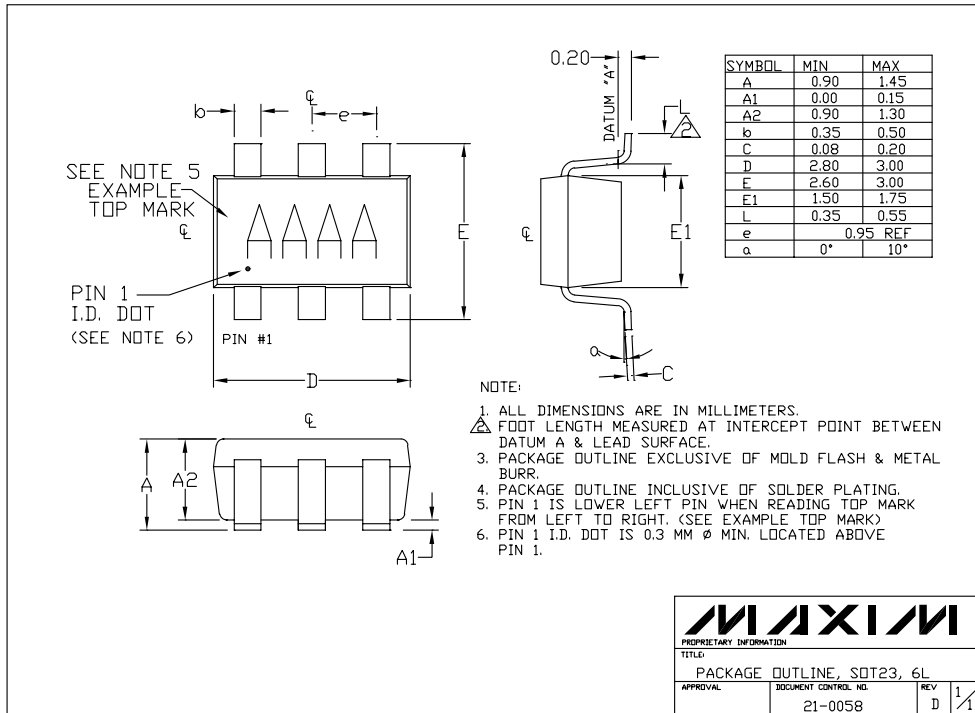

MAXIM			
<small>PROPRIETARY INFORMATION</small>			
<small>TITLE</small>			
PACKAGE OUTLINE, SOT23, 6L			
<small>APPROVAL</small>	<small>DOCUMENT CONTROL NO.</small>	<small>REV</small>	<small>1/1</small>
	21-0058	D	

6LS0TEPS

Maxim cannot assume responsibility for use of any circuitry other than circuitry entirely embodied in a Maxim product. No circuit patent licenses are implied. Maxim reserves the right to change the circuitry and specifications without notice at any time.

12 **Maxim Integrated Products, 120 San Gabriel Drive, Sunnyvale, CA 94086 408-737-7600**